

NOZZLE SCHEDULE				
ITEM	QTY.	ITEM CODE	DESC.	NOTES
A	3	TF2CURVED	2" FPT INTO SHELL	
B	1	LIFTLUG2-900SM	SMALL LIFT LUG	RATED 6,800 LBS
C	1	TF1XHFLAT	1" FPT INTO SHELL	

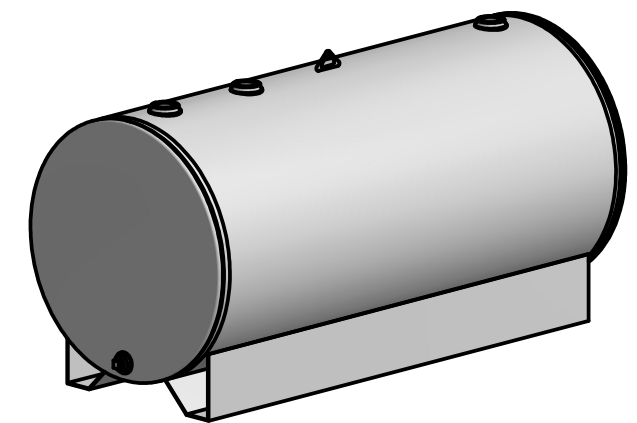

- NOTES:
- CLEAN TANK COMPLETELY AFTER WELDING.
 - INSPECT TANK FOR UNDERCUT & CONCAVE WELDS BEFORE SECOND TEST.
 - SECOND TEST TANK AFTER SILLS ARE WELDED.

PRODUCT CODE: SW150FSK28D		DESCRIPTION: 150 GALLON NON-UL SINGLE WALL SKID TANK			STEEL TANK & FABRICATING CORP.		
FOR: STOCK		CUSTOMER APPROVAL:		QUANTITY: 3	CAPACITY: 150 GAL.	APP. WEIGHT: 243 lbmass	COLUMBIA CITY, IN 46725 800-852-9102 / 260-248-8971 / FAX 260-248-8973
PAINT: BLAST / ENAMEL WHITE		<input type="checkbox"/> MAKE NOTED CHANGES AND RE-SUBMIT <input type="checkbox"/> APPROVED WITH CHANGES NOTED <input type="checkbox"/> APPROVED AS DRAWN SIGNATURE: _____		DIAMETER: 28"	LENGTH: 5'-0"	LABEL: NONE	
				MATERIAL: MCS	HEADS: 12GA	SHELL: 12GA	DRAWN BY: KRM
				CUSTOMER ORDER#: -	STAFCO ORDER#: -	SCALE: 1 / 10	CHECKED BY: MDP
						FILE NAME: SW150FSK28D.dwg	DATE: 5/26/2022
						SHEET: 1 OF 1	

